



## Episodic associative memories taught by evolutionary algorithm

Barbara Borowik\*

*Institute of Computer Modelling, Cracow University of Technology,  
ul. Warszawska 24, 31-155 Cracow, Poland*

### Abstract

The paper analyses possibilities of episodic multi-winner multi-directional associative memory taught by evolutionary algorithm. This kind of memory allows to store and recall more complex associations, like episode-to-episode.

### 1. Introduction

One of the purposes of neural networks is the analysis and reproduction of human competencies in information processing, like for example image or speech recognition, the association of events and the recalling of one event from seeing or hearing another. Neural networks try to imitate the basic functions of the human brain structure and because of this they are an important tool in information processing and have already found their applications in data compression, in finding nearly-optimal solutions in combinatorial optimization problems, in the comparing and the recognition of patterns, in the association of information, in the approximation of functions and in many other applications [1-2].

Existing models of associative memory which have been designed and described by many well-known researchers, may perform one association, like auto-association, hetero-association (or both together in the same model) or episodic association. More complicated combinations, like episode-to-episode associations, have not been carried out. Real life applications suggest that there is a great need for the ability to store and recall such complex associations successfully, however, there are not many studies concerning this topic. Therefore, associative memory organization problems are only partially scientifically solved and the majority of these concepts in the literature are still in the stage of theoretical considerations. Associative system models need to improve in efficiency, possess greater functionality as well as flexibility.

---

\* E-mail address: [plborowi@cyf-kr.edu.pl](mailto:plborowi@cyf-kr.edu.pl)

## 2. Competitive nets with many winners

The nature of distributed parallel information processing using neural networks fits more closely into the processing of distributed information than to information represented in a local way [3]. Generally speaking, when we desire to take into consideration the efficiency of information and its robustness to neurons or connection damage - then distributed representation is always better than local [4-6]. One way of obtaining distributed representation in neural nets is the realization of competition with many winners.

An important subject in research about artificial neural nets, especially those functioning as associative memories, is the automatic generation of information that this net is going to remember.

Until 1996, automatic generation of representation of information incoming to the net – had been only proposed for one-layer nets and it has concerned only local representation [7-9]. (There have been no examples of more complex structures.) Additionally, only a few conventional associative memory models use distributed internal representation of remembered information in their net input patterns during the processing of information in them.

Shown in figure 1, multi-winners self-organizing neural network automatically generates distributed representation of incoming information and is the basic model from which more complex models may be built [10].

## 3. Structure of the auto-associative self-organizing neural network with many winners

Structure of the auto-associative model MWSOINN is shown in figure 1 [10]. The MWSOINN net consists of two layers – the communicative (i.e. input-output layer) and the distributed representation one. These two layers are fully connected through two sets of weights. The first set which is shown in figure 1 is denoted by the four-dimensional matrix  $W = [w_{k \leftarrow i j}]$  and is used during the transfer of the input signals to the top layer of the net. Elements of this matrix are weight values of the synaptic connections  $w_{k \leftarrow i j}$ , that lead from every  $(i,j)$  neuron  $((i,j) \in I \times J)$  of the input-output layer to every  $(k,l)$  neuron  $((k,l) \in P \times Q)$  of the distributed representation layer.

The second set consists of weight values of the synaptic connections  $v_{ij \leftarrow kl}$  that lead from every  $(k,l)$  neuron of the distributed representation layer to every  $(i,j)$  neuron of the input-output layer. In figure 1, this set is denoted by the four-dimensional matrix  $V = [v_{ij \leftarrow kl}]$ .

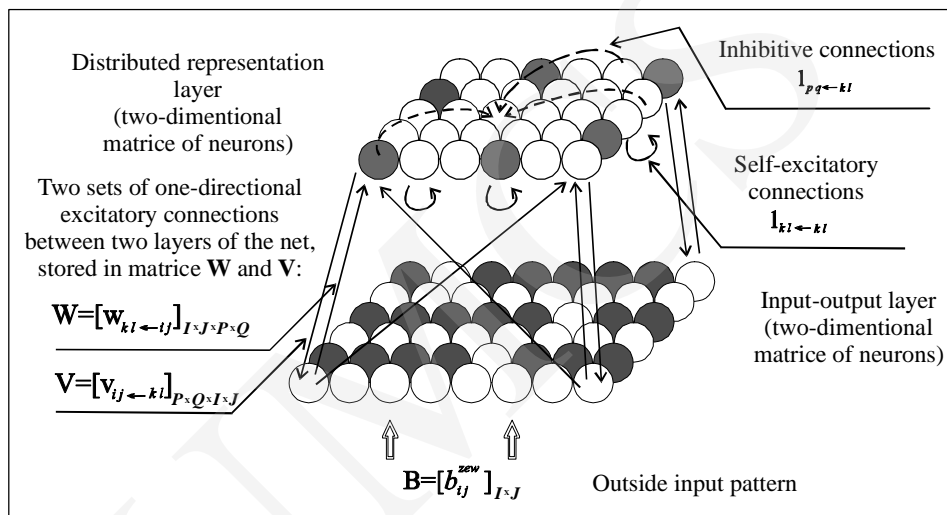

Fig. 1. Structure of the auto-associative MWSONN memory model

The transfer function of neurons in the top layer is the Mexican hat function also referred to as the lateral inhibition rule. This function causes the specific distribution of the weight values of the synaptic connections between the neurons lying in the top layer: i.e. this distribution is excitative between the close units and inhibitive between the further ones, with the weights diminishing to zero while the distance between neurons increases.

Such weight organization (referred to as the "local excitatory neighbor inhibitory") causes as a result of mutual connections, neurons that lie in the close mutual neighborhood and have a tendency of collectively discovering similar input signals, while units with a larger mutual distance favor different signals.

When the MWSONN auto-associative memory receives on its input-output layer the outside information to be memorized, the net with the use of competitive dynamics with many winners, automatically generates in the distributed representation layer – distributed representation of the input information in the form of the excitatory distribution of all the neurons of this layer.

Completion of the competitive procedure is followed by the initial process of the learning procedure that searches for the optimal weight values of all synaptic connections between two layers of the net. These weights are taught by the error

correction learning method (S. Amari, 1994). Because the competitive procedure and the learning procedure of weights are two independent processes, the net may be taught by any other learning algorithm and this will not change the basic rules of this net functioning. The author of this article in order to teach both:  $W$  and  $V$  matrices of weights (fig. 1) used evolutionary methods: classical and non-standard ones, which utilize knowledge about the domain of the function optimizing weight coefficients of synaptic connections between the two layers of this net. The results obtained from the computer simulation outcomes have allowed us to compare the quality of evolutionary methods of learning in this net with the quality of a net, taught by the original analytical method. Some of the results of teaching MWSOINN with an evolutionary program utilize the knowledge specific to this optimization process.

Computational results of this comparison have shown that the convergent speed of the learning processes of  $W$  and  $V$  matrices of weights for the two learning methods (i.e. the evolutionary algorithm which utilized the knowledge about the domain of the optimized function and the original analytical algorithm [10] – was for the same sets of input patterns and for the same sets of their respective distributed representations relatively similar to each other.

The outcome of the simulation confirmed the opinion [11] that the inclusion of knowledge about possible solutions increases the effectiveness of the evolutionary algorithm and makes more effective the searching process of the feasible solution space and that in the case of a large scale task with (in other words a task several thousands of parameter variables), as in our case, decides about the quality of the algorithm.

The convergent speed of the original analytical learning method of the net as a consequence of its high precision and deterministically adaptive determined corrections, and because of this effective in the iterative modification of weights exceeds significantly because of its quality the possibilities of tested classical evolutionary programs. The factor of randomness, introduced in the modification steps while creating new chromosomes and their coded thousands of variable weight connection values which in our case additionally have been multiplied by around 100 (i.e. the number of input patterns in the entry set to this net) – in all of the tested versions of classical genetic algorithms have caused meaningful degradations of its convergence process.

Computer simulations have also shown that MWSOINN memory as an auto-associative net, has advantages which could be summarized by the following points:

- 1) the MWSOINN net is able to:
  - process analog patterns;
  - generate automatically analog distributed representations for all information stored in these net input patterns.

Relations between the input analog patterns and their distributed representation have been remembered in two-directional asymmetrical weight connections between both layers of this net.

- realize auto-association.
- 2) the efficiency of the distributed representations in the MWSONN net is high;
- 3) the storage capacity of MWSONN net exceeds the capacity of nets that are using local information representation;
- 4) the MWSONN net possesses high resistance for noise in input patterns;
- 5) the resistance to neuron damage in the distributed representation layer and to the damage of the synaptic connections leading to the other layer of the net is high.

The MWSONN model may be extended to many other models, like to the hetero-associative model (MWAM) [12], to the episodic model (EMWAM) [13], to two-directional episodic associative model (CMWAM) [14] and to the multi-directional episodic associative model (CMW-MAM) [6]. Figure 2 shows the example of the memorization process of a couple of: ('k'  $\leftrightarrow$  'K').

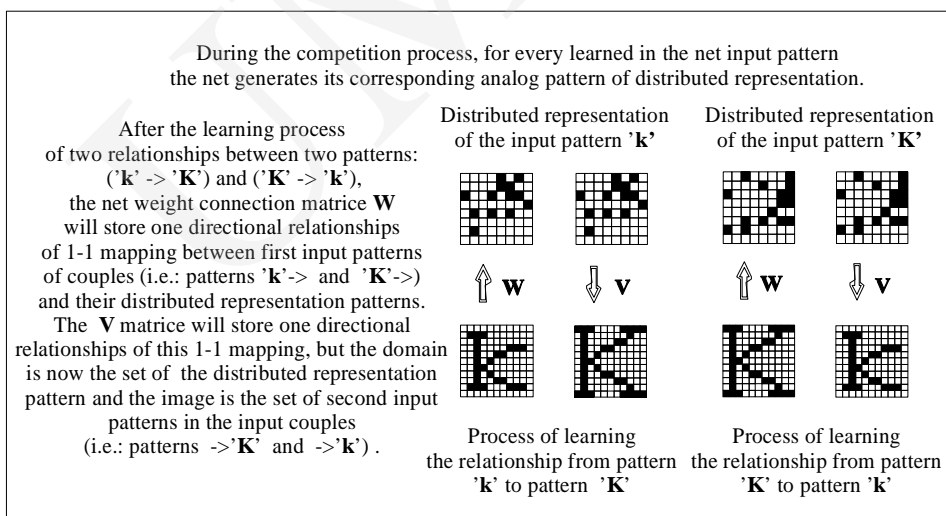

Fig. 2. The process of storing in the MWAM net couple patterns: ('k'  $\leftrightarrow$  'K')

The MWAM memory is architectonically identical with the MWSONN net. The differences between those nets lie in the small changes within the pattern memorizing process, in order to take into consideration the hetero-associativity of the pattern recalling operation in the MWAM net, which is in opposition to the auto-associative operation within the MWSONN memory.

The second extended associative memory model of the MWSONN model is the episodic associative memory EMWAM one with its many winners [13].

The EMWAM net may memorize many sequences of patterns. The process of memorizing patterns is nearly identical to its corresponding process in the MWAM net with the difference, that instead of memorizing in the net the set of  $L$  independent couple of patterns:  $(A_i, B_i)$ , in the EMWAM net each couple is "tied up" with the pattern adjacent in this sequence, i.e. this net memorizes additionally couples  $(B_i, A_{i+1})$  (for  $i=1, \dots, L$ ) and couple  $(B_L, A_1)$ .

The third extended associative memory model (i.e. the CMWAM net) has been constructed from the two EMWAM nets: two distributed representation layers of two EMWAM nets are fully connected through one-directional weight connection. This is shown in Figure 3.

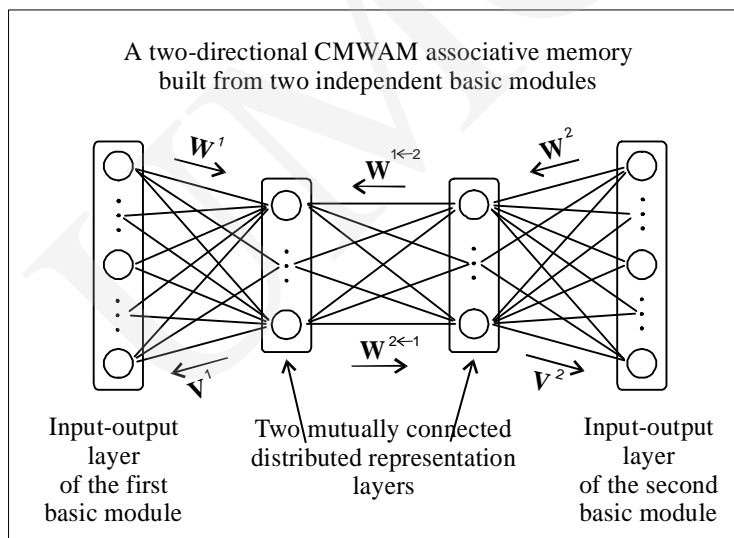

Fig. 3. Structure of the CMWAM model

This net, like the EMWAM one, is able to remember and successfully recall various associative constructions such as auto-associations, hetero-associations and episodic associations.

Additionally, this net is able to remember relationships between any different associations that when adequately used in applications the CMWAM net remembers the information hierarchically.

The last extended associative memory model of the MWSONN net is the CMW-MAM memory [6]. This net offers many new possibilities not obtained yet in any of the existing associative memory models: it allows for remembering

many sequences of patterns and connections between them and gives the possibility of recalling all these sequences or any one of them by presenting in the net entry any pattern from any remembered earlier sequence.

Figure 4 illustrates the simplest CMW-MAM net constructed from three other basic models. Three layers of distributed representations of three basic modules have been fully connected through the sets of one-directional weight connections. The architecture of a part that connects these three mentioned layers is similar to that possessed by the three layer MAM model, which allows for regarding this net as a new many-directional memory.

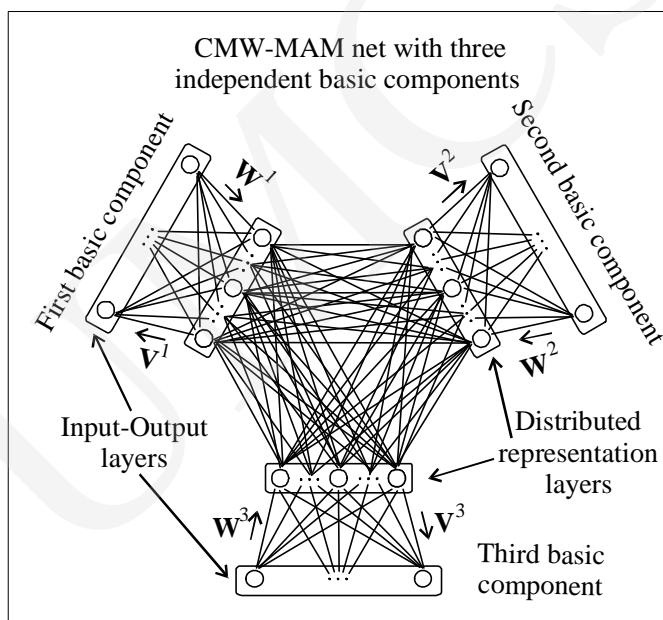

Fig. 4. Structure of the CMW-MAM model

In the CMW-MAM model each of the basic models may realize any basic associations, i.e. auto-association, hetero-associations and episodic associations depending on various applications of this module and corresponding learning processes [6]. Because a basic module may realize all three kinds of associations, the CMW-MAM net may realize a more complex group associations like many-to-many, which are mutually correlated through weight connections between the layers of distributed representations.

### References

- [1] Tadeusiewicz R., *Problemy biocybernetyki*, PWN, Warszawa, (1993), in Polish.
- [2] Tadeusiewicz R., *Badanie funkcjonowania mózgu za pomocą sieci neuronowych*, in collective work: *Kognitywistyka i Media w Edukacji*, 1 (1998) 169, in Polish.

- [3] Rumelhart D.F., McClelland J.L., PDP Research Group, *Parallel Distributed Processing*, MIT Press, I and II (1989).
- [4] Hecht-Nielsen R., *Neurocomputing*, Addison-Wesley, Reading, MA, (1990).
- [5] Hertz J., Krogh A., Palmer R.G., *Wstęp do teorii obliczeń neuronowych*, WNT, Warszawa, (1993).
- [6] Huang J., Hagiwara M., *A new multidirectional associative memory based on distributed representation and its applications*, Proc. IEEE Int. Conf. on Systems, Man & Cybern., Tokyo, Oct., (1999) 12.
- [7] Amari S., *Mathematical Theories of Neural Networks*, (1978).
- [8] Fukai T., Tanaka S., *A simple neural network exhibiting selective activation: from winner-take-all to winners-share-all*, Neural Computation, 9 (1997) 77.
- [9] Majani E., Erlarson R., Abu-Mostafa Y., *On the K-winners-take-all network*, Advances in Neural Information Processing Systems, (1989) 634.
- [10] Huang J., Hagiwara M., *A multi-winners self-organizing neural network*, Proc. IEEE Int. Conf. on Systems Man and Cybernetics, Orlando, 3 (1997) 2499.
- [11] Michalewicz Zb., *Algorytmy genetyczne+struktury danych+programy ewolucyjne*, WNT, Warszawa, (1996).
- [12] Huang J., Hagiwara M., *A multi-winner associative memory*, IEICE Trans. on Information and Systems, vol. E82-D, 7 (1999) 1117.
- [13] Huang J., Hagiwara M., *Multi-winners self-organizing episodic associative memory*, Proc. IEEE Int. Conf. on Systems, Man and Cybern., San Diego, (1998) 3635.
- [14] Huang J., Hagiwara M., *A combined multi-winners multidirectional associative memory*, Proc. IEEE Int. Joint Conf. on Neural Networks, Washington D.C., (1999).
- [15] Hagiwara M., *Multidirectional associative memory*, Proc. IEEE & INNS Int. Joint Conf. on Neural Networks, (1990) 3.